

GCO GripGraphic Banner Stands™

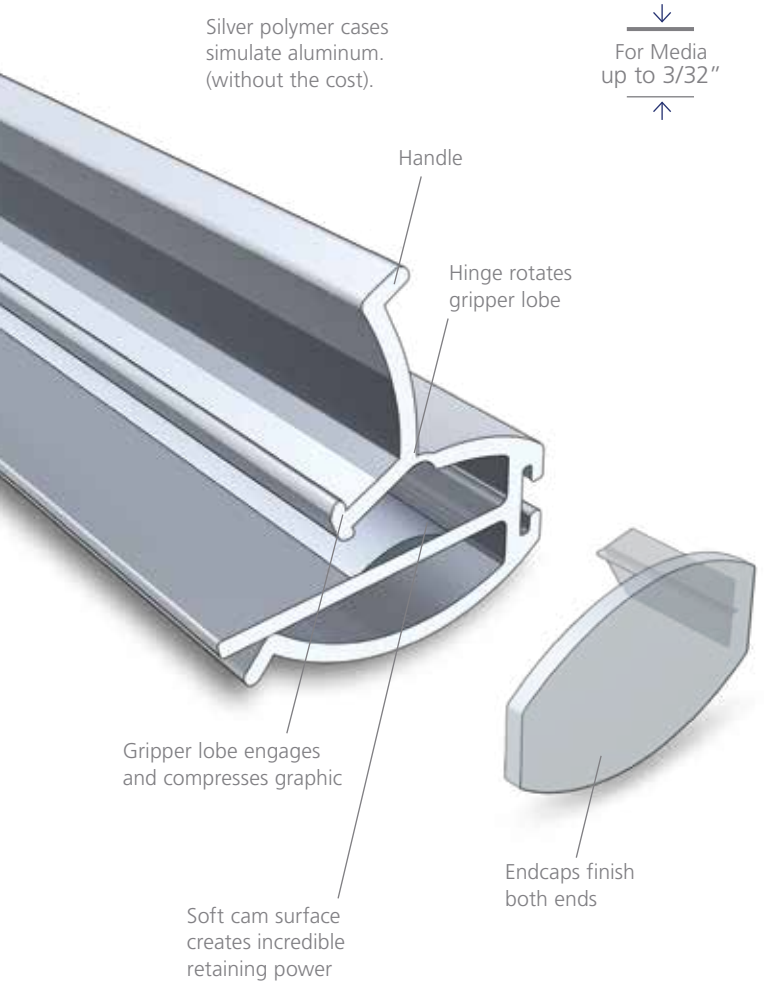

GripGraphic Bars™

Oval co-extruded bars deliver exceptional gripping power at an economical price point.

- No pockets or graphic end treatment required
- Closes easily once graphic is inserted
- Telescopic upright holds graphics up to 96" high
- Bars hold 24" wide graphic media to 3/32" thick

No pockets or graphic end treatment required!

GCOBS1	Holds one 24" Banner
GCOBS2	Holds two 24" Banners

Satin Silver Finish

Patented Technology!
 U.S. Utility Patent # 6,637,716
 U.S. Design Patent # D-424,120



Accessories



Literature baskets

